

440 Regina

Start of a new generation of yachts



MARINE
SCA
CANADIAN & UNITED STATES DISTRIBUTOR



INDEX

- Development Team & Supply Partners
- Technical specifications
- Performance
- Engine room
- Installations
- Electronics
- Key Points
- Interior
- Standard and Optional
- Sales Topics
- Competitors

THE NEW DEVELOPMENT TEAM

Alessandro Lottici - Exterior Designer

2005-2020 Head designer Officina Italiana Design
(Riva-Sanlorenzo)

Arianna Bianchi – Interior Designer

Senior Architect LD Design
Interior design at Absolute
Active collaborations with Gruppo Ferretti

Matteo Maj - Engineering

2003-2010 Molds Manager Riva
2010-2023 Founder Wedo Engineering

Giuseppe Martines - Engineering

Senior Designer Garroni Progetti Prestige - Janneau
Senior Designer Pastrovich
Engineering Bluegame

Massimo Radice – General Manager

2017-2022 Operation Manager Bluegame
2015-2017 General Manager Persico
2010-2015 Vice President Intech Sessa Brasil
1995-2010 Operation Manager Sessa Marine

Stefano Milanese – Naval Architect

PhD Università Federico Secondo Napoli
1998-2006 Production Director Conam Technical
2004-2005 Director Itama
2006-2023 CEO Naval Design e Consulting

Carmine Baiano - Technical Coordinator

Production Director at Uniesse
Production Manager Bluegame line at Over Sea
Production Director and Technical Coordinator FIM

Mirko Mendola - Engineering-Installations

Valentina Sessa - Engineering Interior

Mattia Ferrario - Engineering Interior

Maria Nicolosi - Engineering Composite and Molds



IMPORTANT PATNERS IN PRODUCT DEVELOPMENT

SUPPLIER	AREA	OTHER CUSTOMERS
Tappezzeria Nautica	Wallpapers	Riva - Sanlorenzo
Arredarte	Furnishings	Absolute
Navyonica	Electrical Installations	Bluegame
CBS	Carbon parts	Ferrari-Aston Martin-Augusta Westland
Mondo Yacht	Carbon Hard Top	Bluegame – Sanlorenzo
Balteck	Teak	Sunseeker – Windy
OM Project	Stainless Steel	Azimut Benetti

TECHINICAL SPECS

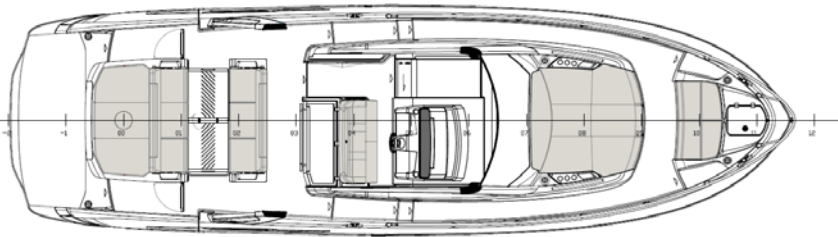
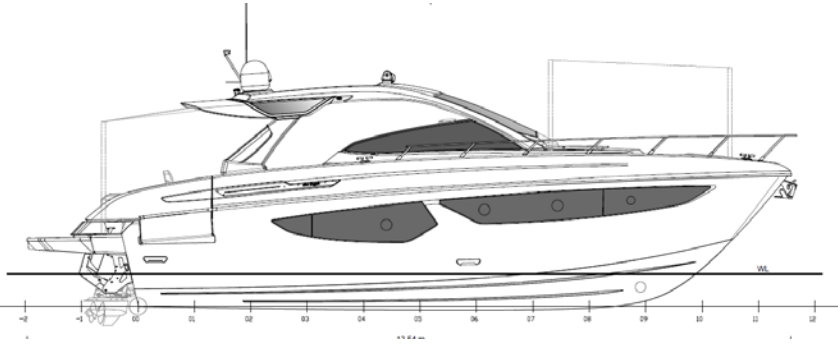

Lunghezza fuori tutto	LOA	13,60 m
Lunghezza scafo	LT	11,80 m
Larghezza	Beam	4,00 m
Altezza costruzione	Ht	4,00 m
Bordo Libero	Free Edge	1,80 m
Peso secco	Dry Weight	12 ton
Peso Pieno Carico	Full Load weight	13 ton
Immersione Pieno Carico	Draft	0,7 m

IMPORTANT PATNERS IN PRODUCT DEVELOPMENT

SUPPLIER	AREA	OTHER CUSTOMERS
Tappezzeria Nautica	Wallpapers	Riva - Sanlorenzo
Arredarte	Furnishings	Absolute
Navyonica	Electrical Installations	Bluegame
CBS	Carbon parts	Ferrari-Aston Martin-Augusta Westland
Mondo Yacht	Carbon Hard Top	Bluegame – Sanlorenzo
Balteck	Teak	Sunseeker – Windy
OM Project	Stainless Steel	Azimut Benetti



**29 AUGUST 2023 - NAVIGATION TEST
@ ISEO LAKE - ITALY**

Engine: 2 x Volvo Penta D6 440 hp

Prop: H5

Testing Weight: 13 ton

Crew: 7

Speed: 38 kn

0-20 kn: 10 sec

Cruising speed: 23 kn

Cons: 90 lt/h

PERFORMANCE

GIRI	NODI	ASSETTO (1)	CARICO ELICA	TRIM MOT	TRIM INTRUDER	CONSUMO lt/h	DB * PLANCIA
1000	6	2°	30%	-5	-80	8	66
1500	8	2,5°	42%	-5	-100	22	72
2000	10	3°	61%	-5	-100	56	76
2500	17	3,5°	70%	-4	-90	84	80
2800	23	4°	65%	-4	-80	94	82
3000	27	1°	70%	-3	-50	110	82
3500	33	1°	90%	0	-30	170	83
3800	38	1°	98%	0	-20	175	83

VELOCITA PLANATA

17

GIRI

2400

T PLANATA

7"

ACCELERAZIONE 0-20 nodi

10"

ACCELERAZIONE 0 30 NODI

17"



ENGINES ROOM

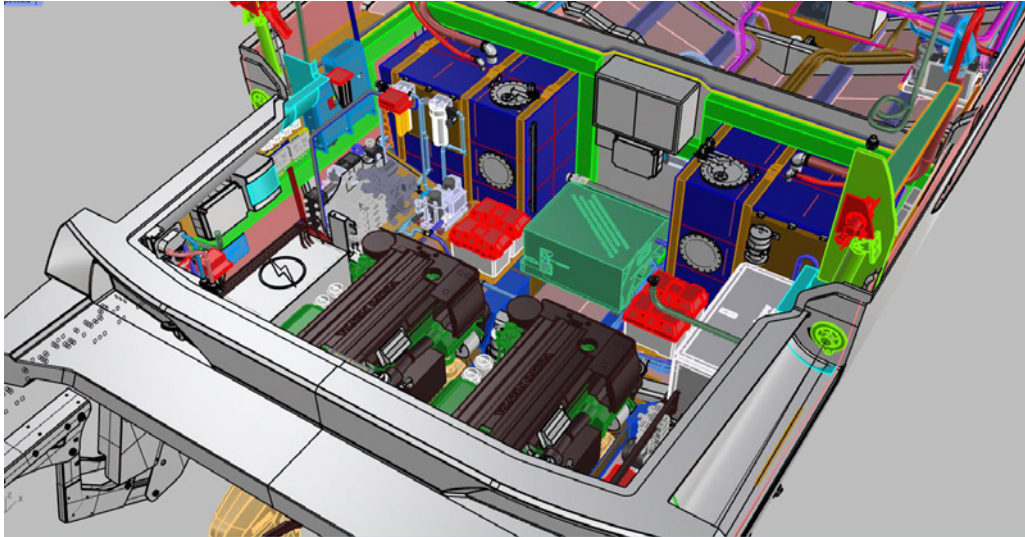

- Front stainless-steel tanks with external level check - front cleaning inspection, connection valves.
- 30 mm insulation throughout the engine room;
- Easy access to electrical services
- Spacefull engine room
- Easy access with ladder and platform

ENGINE ROOM BULKHEAD IN LIGHTWEIGHT SANDWICH

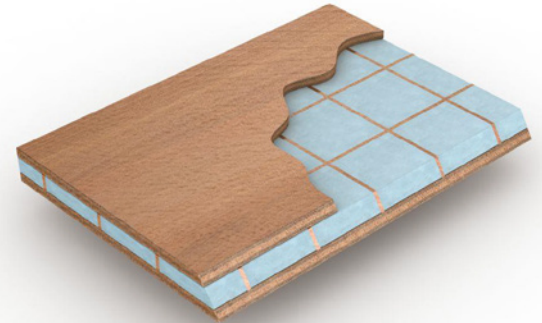
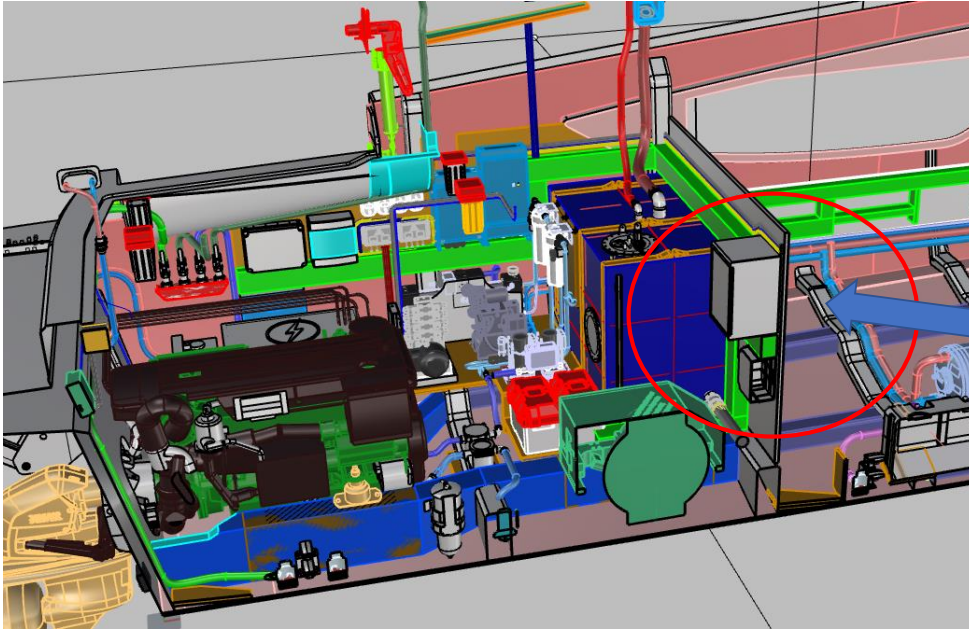

- Low specific weight
- High mechanical performance
- High compressive strength
- Cabin soundproofing

SYSTEM NETWORK

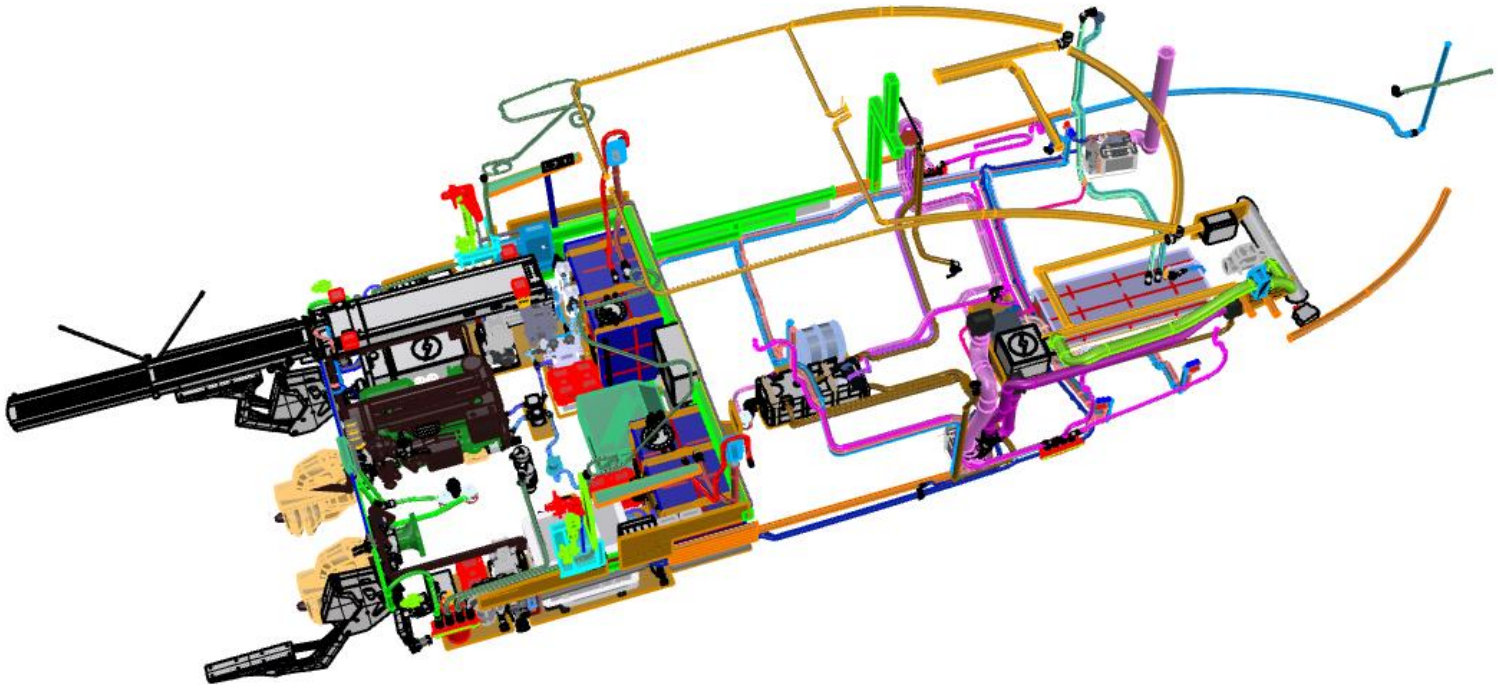

SYSTEMS WITH DISCONNECTION OF HYDRAULIC LINES FOR EVERY SERVICE

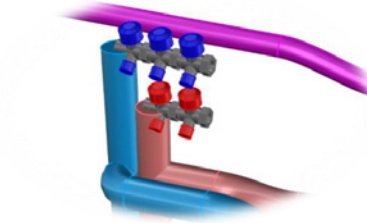
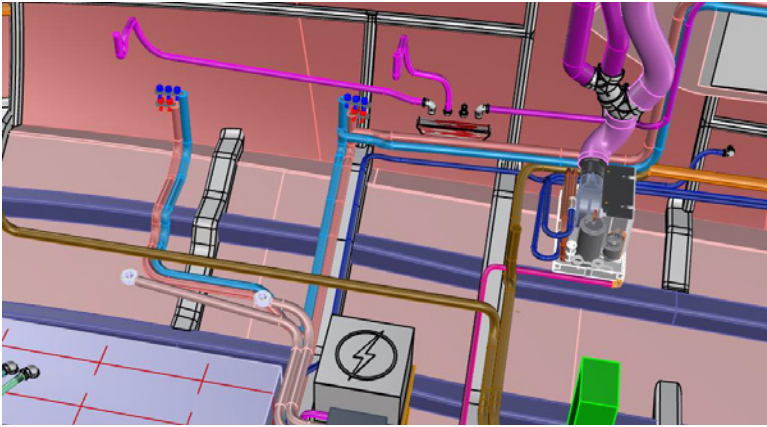

CENTRALIZED EXHAUSTS COLLECTED AT THE SIDE WITHOUT EXTERNAL VISIBILITY

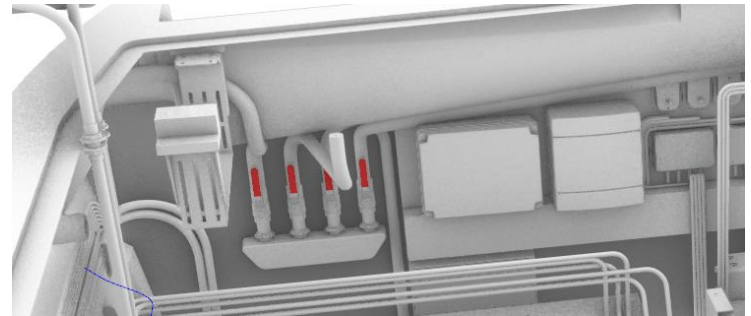

AIR CONDITIONING SYSTEM



- MED SYSTEM 18.000 BTU
- 2 compact units 9.000 BTU
- TROPICAL SYSTEM 24.000 BTU
- 2 compact units 12.000 BTU
- AC in the cabin and in the toilet
- Self priming pump and filter in engine room

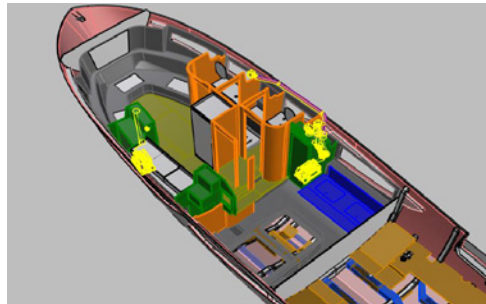
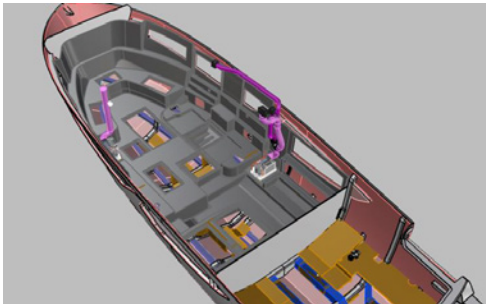

GENERATOR



- Assembly with anti-vibration mats
- Water-fume separator
- Digital detection panels in home automation



MEDITERRANEAN VERSION 6 KW IS 6.05i

- Compact and light group 130 Kg 3.000 rpm
- Yanmar L100 engine
- Silenced version
- Noise 62 dBA
- Maximum power 6 kW
- Continuous power 4.8 kW
- Integrated inverter

TROPICAL VERSION 8 KW IS 9.5

- Very silent 1,500 rpm Kubota engine
- Maximum power 8 kW
- Continuous power 7.2 kW
- Noise level 50 db
- Integrated inverter

DOMOTIC STANDARD SYSTEM



Raymarine

NAVIGATION

WIPER
ON



UNDERWATER
LIGHTS



WIPER
TIMER



ENGINE ROOM
LIGHTS



WIPER
WASH



ENGINE ROOM
FLOOD ALARM

CABIN
FLOOD ALARM

COCKPIT
LIGHTS



ENTRANCE STAIRS
COURTESY LIGHTS



NAVIGATION
SCENARIO

NIGHT DINNER
SCENARIO

ALL NAV.
LIGHTS ON

ALL NAV.
LIGHTS OFF

HARD-TOP LIGHTS



COCKPIT
COURTESY LIGHTS



NAVIGATION



LIGHTS



POWER



FLUIDS

Raymarine

CABIN LIGHTS

OWNER CABN LIGHTS



OWNER WC LIGHTS



OWNER CABIN COURTESY LIGHTS



SHOWER LIGHTS



SOFT CABIN LIGHTS SCENARIO

SOFT DINETTE LIGHTS SCENARIO

ALL INT. LIGHTS ON

ALL INT. LIGHTS OFF

ENTRANCE GALLEY LIGHTS



BOW WC LIGHTS



BOW CABIN COURTESY LIGHTS



BOW CABIN LIGHTS



NAVIGATION



LIGHTS



POWER



FLUIDS

Raymarine

POWER

PORT ENGINE
BATTERIES

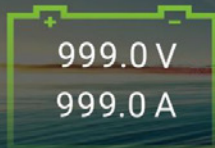

SERVICE
BATTERIES



STBD ENGINE
BATTERIES



INVERTER

NAVIGATION

LIGHTS

FIM

POWER

FLUIDS

Raymarine®

FLUIDS

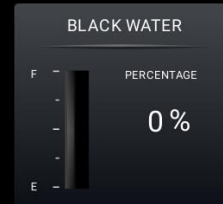
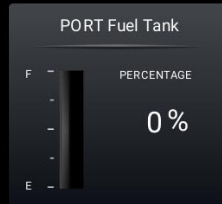
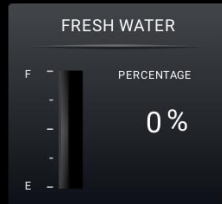

EXTERIOR STRENGTHS

- Central Drive Console;
- Walk all-around;
- Side decks with 90 cm restraint in the cockpit and 40 cm in the all-round walk;
- Habitability of the bow area during navigation with double facing sofa and aperitif table;
- Full-length side windshield with wind protection during navigation (a plus compared to traditional walk around boats);
- Cockpit convertible into navigation seat and sun position;
- Hard Top in carbon with slatted roof 4 m² of openable surface;
- Spherical tempered glass in double curvature;
- Stainless steel mooring hawse treated as design element
- Cushions made with dryfil rubbers, sky Spradling USA – Riva upholsterer supplier;
- Electrical system with standard home automation (dimmer, panel monitoring and remote management);
- Extended platform hydraulic movement and foldable wings cockpit 15 sq mt beam 5 mt
- Stern platform spacefull (1,7 mt) with deep draft 80 cm
- Teak with 45° line style FIM



INTERIORS STRENGTHS

- Great internal habitability
- Aft cabin height 158 cm;
- Central dinette height 195 cm;
- Bathroom height 198 cm;
- Dinette height 191 cm;
- Lateral brightness by large glass surfaces 3.5 mq 7 flush portholes;
- Entrance width cm 2 mt and large ergonomic stairway with wooden design handle and LED underneath.



INTERIOR KEY POINTS

- Innovative room layout with owner's entrance;
- Double bathroom with communicating shower like in mega yachts (boat show version shower light glass standard with fume glass for better privacy)
- Research of innovative and different materials compared to the couplings market standards
- Furniture with matt and brushed lacquers combined with 100 gloss gloss details;
- It is interesting to present the three-dimensional panel in the owner's cabin and in toilet;
- 225-litre refrigerator column with microwave housing that leaves the kitchen free and spacious;
- Refined and covering vertical cushions like home sofas, creating true design components;
- Fantini matt black taps and high-quality accessories;
- Inspection of all cabinet bottoms with quick opening systems for maintenance and after-sales -
- Storage equipped for inserting dishes, glasses and cutlery (kit available).





Living



Sleeping



2000 x 1400 twin bed

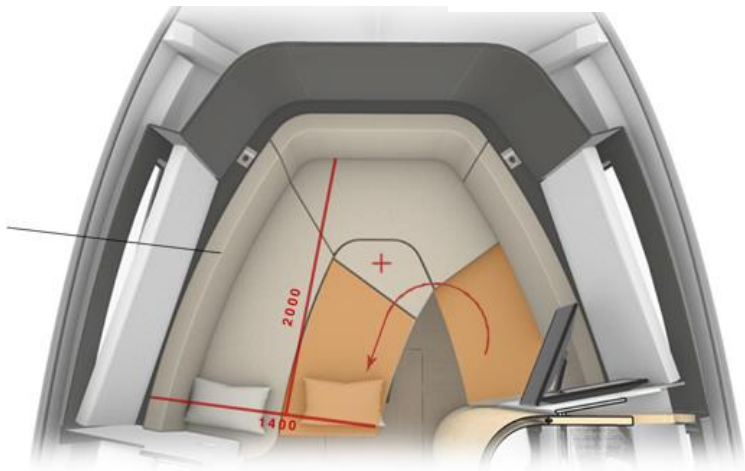

RAYMARINE DOCK SENSE

The Raymarine DockSense™ control assisted docking system is the recreational marine industry's first assisted docking solution with object recognition and motion sensing. DockSense™ Control systems use FLIR industrial intelligent camera technology to analyze real-world images and integrate them with the vessel's steering and propulsion systems to assist owners in docking maneuvers in confined spaces.

6 CAMERAS



6 CAMERAS

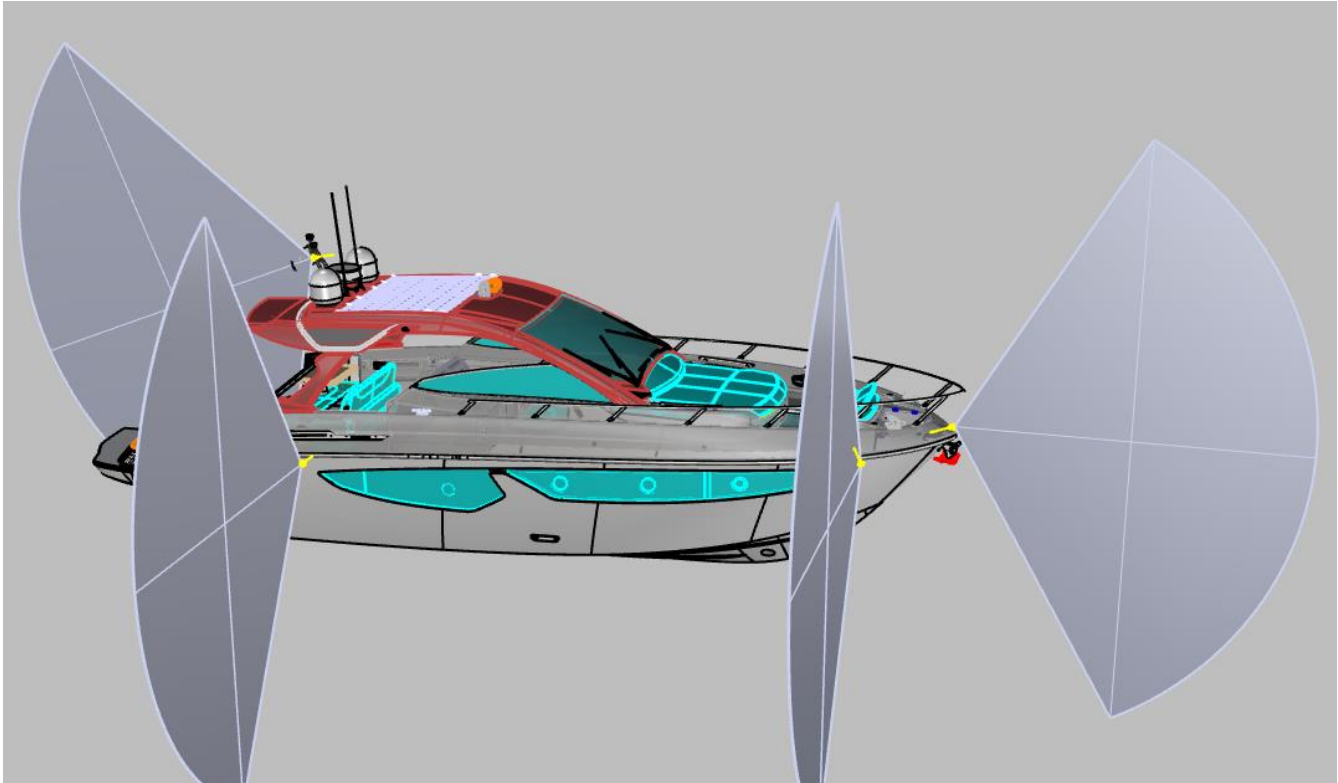



USE OF CARBON FIBER COMING FROM CIRCULAR ECONOMY

For the construction of the FIM 440 Regina, in particular, the shipyard decided to use carbon fiber made with the technology developed by Recarbon of Busto Arsizio in partnership with CBS, which involves the regeneration of fiber from the aeronautical sector. An eco-sustainable choice with the aim of reducing the environmental impact and creating a circular economy also for composite materials which, first in the nautical world, FIM wanted to pursue. The recycled carbon fiber from the aeronautical sector, through regeneration processes, in fact retains characteristics close to the original product. Its use in superstructures therefore solves two important problems: that of lightness, especially in the highest part of boats, by lowering their center of gravity, and that of stability at high temperatures, thanks to the resistance of this material up to temperatures of 100 degrees.

MAIN COMPETITORS 42-45 ft

MODELLO	LFT	B	WEIGHT	CABIN	ENGINE
FIM 440	13,55	4	14	2	Efb380
Pardo 43	13,44	4,2	10	2	IPS500
Cranchi LT 46	14.25	4,33	10	2	IPS600
Invictus 420	12,3	4,15		1	Efb380
Solaris 44	13,47	4,35	11,5	2	IPS500
Janneau DB43	13	3.80			Efb380



SOLD BY



EXCLUSIVE DISTRIBUTOR FOR CANADA AND UNITED STATES



MONTREAL 514 642-5784
TORONTO 647 276-0578
NEW YORK 332 282-5878

info@marine-sca.com

228-1000 Montée des Pionniers
Terrebonne, Québec Canada
J6V 1S8

www.marine-sca.com



SCAN THE
BUSINESS CARD